

MOT series

5,000kg / 7,000kg

Tow Tractor



- Scooter control steering device enhances ergonomics and productivity
- CANbus technology and high IP protection for main components
- Efficient energy management

Truck Dimensions

MO50T/MO70T

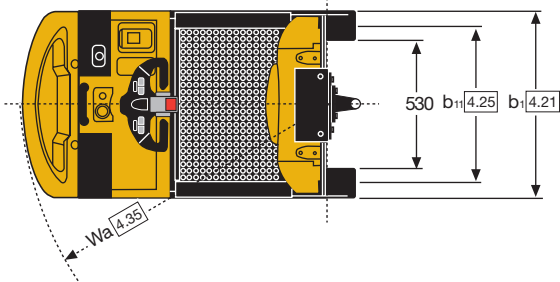

$$Ast = Wa + R + a$$

$$Ast = Wa + \sqrt{(l_6 - x)^2 + (b_{12} / 2)^2} + a$$

$$a = 200\text{mm}$$

MO70T

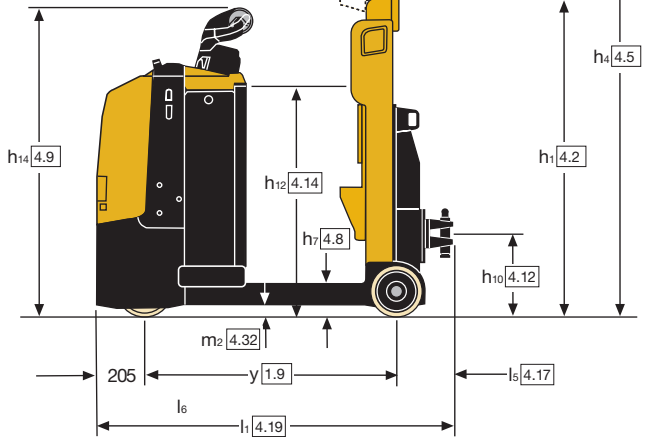
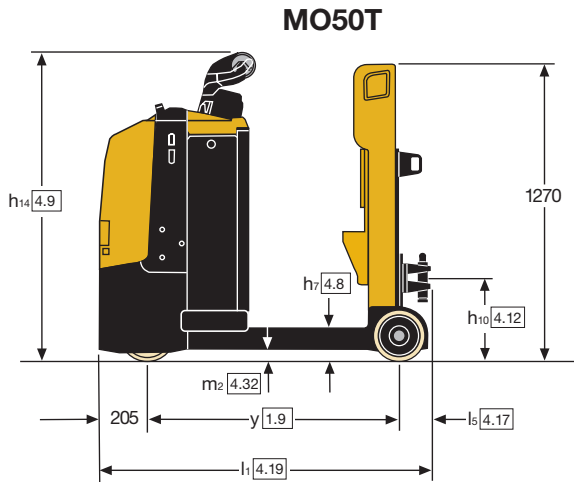

Performance - MO50T

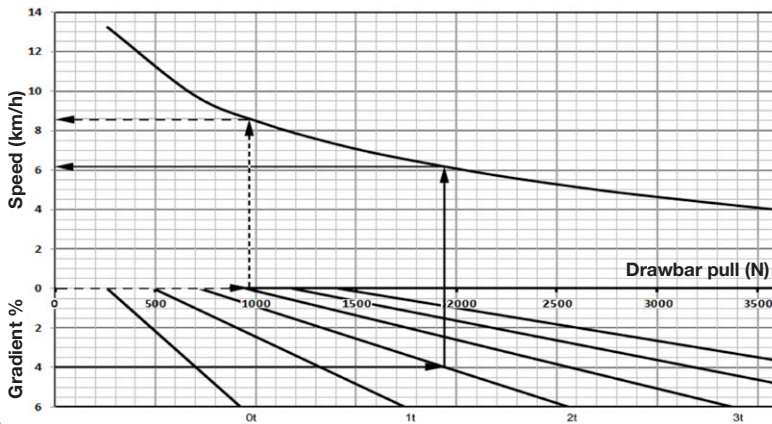

How to read the diagram

Dashed line: The MO50T travels on level ground with a load of 3000kg. It requires approximately 965N tractive power for this and reaches approximately 8.5km/h.

Solid line: The MO50T is to travel up a 4% gradient with a load of 2000kg. It requires approximately 1930N tractive power for this and will reach approximately 6.1km/h.

Note: No continuous operation is possible for MO50T over 1000N.

The utilisation of braked trailers is recommended for up/down gradients of more than 4%.

Performance - MO70T

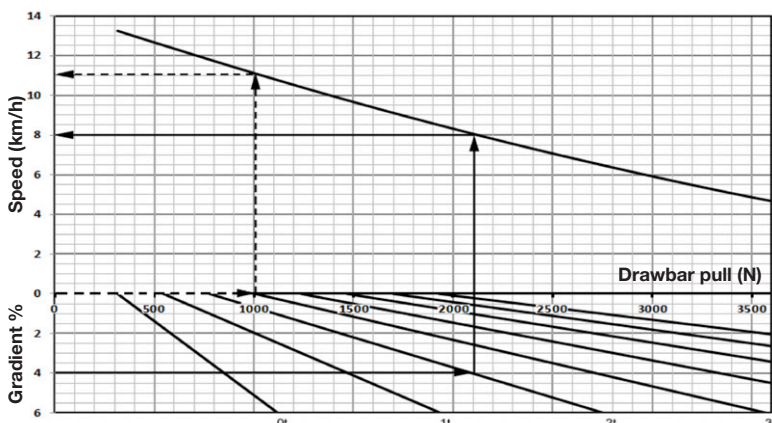

How to read the diagram

Dashed line: The MO70T travels on level ground with a load of 3000kg. It requires approximately 1000N tractive power for this and reaches approximately 11km/h.

Solid line: The MO70T is to travel up a 4% gradient with a load of 2000kg. It requires approximately 2100N tractive power for this and will reach approximately 8km/h.

Note: No continuous operation is possible for MO70T over 1336N.

The utilisation of braked trailers is recommended for up/down gradients of more than 4%.

VDI 2198 – General Specifications

			Yale	Yale	Yale	Yale	
Distinguishing mark	1.1	Manufacturer (abbreviation)		Yale	Yale	Yale	
	1.2	Manufacturer's type designation		MO50T	MO50T	MO70T	MO70T
	1.3	Drive: electric (battery or mains), diesel, petrol, fuel gas		Electric (battery)	Electric (battery)	Electric (battery)	Electric (battery)
	1.4	Operator type: hand, pedestrian, standing, seated, order-picker		Order-picker	Order-picker	Order-picker	Order-picker
	1.5	Rated capacity/Rated load	Q (t)	5.0	5.0	7.0	7.0
	1.7	Rated drawbar pull	F(N)	1000	1000	1336	1336
Weights	1.9	Wheelbase	y (mm)	1229 ⁽¹⁾	1229 ⁽¹⁾	1229 ⁽¹⁾	1229 ⁽¹⁾
	2.1	Service weight ⁽⁵⁾	kg	1136 ⁽¹⁾	1280 ⁽¹⁾	1236	1380
Tyres/chassis	2.3	Axle loading, unladen front/rear	kg	699 / 437	665 / 615	694 / 542	660 / 720
	3.1	Tyres: polyurethane, tophane, vulkollan, front/rear		Vulkollan / Polyurethane	Vulkollan / Polyurethane	Tophane / Polyurethane	Tophane / Polyurethane
	3.2	Tyre size, front	ø (mm x mm)	254 x 90	254 x 90	254 x 90	254 x 90
	3.3	Tyre size, rear	ø (mm x mm)	200 x 100	200 x 100	200 x 100	200 x 100
	3.5	Wheels, number front/rear (x = driven wheels)		1 x /2	1 x /2	1 x /2	1 x /2
	3.7	Tread, rear ⁽⁶⁾	b ₁₁ (mm)	686	686	686	686
Dimensions	4.2	Height, mast lowered	h ₁ (mm)	-	1360	-	1360
	4.5	Height, mast extended	h ₄ (mm)	-	2190	-	2190
	4.8	Seat height relating to SIP/stand height	h ₇ (mm)	152	152	152	152
	4.9	Height drawbar in driving position min./max.	h ₁₄ (mm)	1317	1317	1317	1317
	4.12	Coupling height	h ₁₀ (mm)	365	365	365	365
	4.14	Stand height, elevated	h ₁₂ (mm)	-	980	-	980
	4.17	Overhang	l ₅ (mm)	135	205	135	205
	4.19	Overall length	l ₁ (mm)	1569 ⁽¹⁾	1639 ⁽¹⁾	1569 ⁽¹⁾	1639 ⁽¹⁾
	4.21	Overall width	b ₁ /b ₂ (mm)	796	796	796	796
	4.32	Ground clearance, center of wheelbase	m ₂ (mm)	50	50	50	50
	4.35	Turning radius	W _a (mm)	1434 ⁽¹⁾	1434 ⁽¹⁾	1434 ⁽¹⁾	1434 ⁽¹⁾
Performance data	5.1	Travel speed, laden/unladen	km/h	7 / 13	7 / 13	8.4 / 13	8.4 / 13
	5.1.1	Travel speed, laden/unladen, backwards	km/h	- / 8	- / 8	- / 8	- / 8
	5.2.2	Lift speed, laden/unladen (Cab)	m/s	-	0.189 / 0.189	-	0.189 / 0.189
	5.3.2	Lowering speed, laden/unladen (Cab)	m/s	-	0.162 / 0.162	-	0.162 / 0.162
	5.5	Drawbar pull, laden/unladen	N	1000	1000	1336	1336
	5.6	Max drawbar pull, laden/unladen	N	3000 ⁽⁷⁾	3000 ⁽⁷⁾	4500	4500
	5.8	Max. gradeability, laden/unladen	%	3.4 / 20	3.4 / 20	3 / 20	3 / 20
	5.10	Service brake		Electromagnetic	Electromagnetic	Electromagnetic	Electromagnetic
Electric engine	6.1	Drive motor, S2 60 min rating	kW	2.6	2.6	3	3
	6.2	Lift motor S3 15% rating	kW	-	2	-	-
	6.3	Battery according to DIN 43531/35/36 A,B,C, no		no	no	no	no
	6.4	Battery voltage/nominal capacity K5	(V)/(Ah)	24 / 620 ⁽¹⁾	24 / 620 ⁽¹⁾	24 / 620 ⁽¹⁾	24 / 620 ⁽¹⁾
	6.5	Battery weight ⁽⁵⁾	kg	480	480	480	480
	6.6	Energy consumption according to VDI cycle ⁽⁴⁾	kWh/h at no. of cycles	1.82	1.82	2.37	2.37
8.1	Type of drive unit		AC-Controller	AC-Controller	AC-Controller	AC-Controller	
10.7	Sound pressure level at the driver's seat	dB (A)	< 65	< 67.5	< 65	< 67.5	

⁽¹⁾ Available battery 465Ah. With battery 465Ah -145mm, and service weight -114kg

⁽²⁾ Available battery 500Ah. With battery 500Ah service weight -2kg

⁽³⁾ Applies to 2 pallets = 2400mm

⁽⁴⁾ Values obtained with 40 cycles

⁽⁵⁾ These values may vary of +/- 5%

⁽⁶⁾ With forks "CHEP long" e = 223mm, b₁₁ = 447mm

⁽⁷⁾ With drive wheel in tophane: 3200N

⁽⁸⁾ Transfer aisle widths (lines 4.34.1 & 4.34.2) are based on the VDI standard calculation as shown on illustration.

The British Industrial Truck Association recommends the addition of 100mm to the total clearance (dimension a) for extra operating margin at the rear of the truck.

All values are nominal values and they are subject to tolerances. For further information, please contact the manufacturer.

Yale products might be subject to change without notice

Lift trucks illustrated may feature optional equipment.

Values may vary with alternative configurations.

MOT series

Models: MO50T, MO70T



Tow Tractor

Designed for use in a wide range of manufacturing applications, particularly for line-feed operations

Productivity

- The powerful high thermal capacity 2.6kW or 3kW AC drive motor delivers high performance acceleration, braking and travel speed, making these models ideal for stop and go operations.
- Acceleration, travel and braking speeds can be adjusted by a service engineer to the particular needs of the application through the operator console
- Effortless electrical steering and automatic speed reduction on cornering ensure excellent control and high productivity
- The anti-roll back on ramps device ensures efficient operation
- A maximum travel speed of 13km/h reduces travel time on long runs between docking and picking areas
- Vertical or lateral battery extraction is available

Ergonomics

- Scooter control with electric steering reduces the arm movement required to change direction. This allows the operator to remain within the truck footprint at all times for protection as well as reducing operator fatigue and increasing productivity
- A personnel sensor, which covers the entire platform floor area detects when the operator is on board. This, together with the high, soft touch, back rest, allows the operator to locate the most comfortable operating position
- The large platform area increases operator comfort and allows easier pass through
- Slow-speed forward and reverse direction buttons (coasting function) are located on the backrest.

Cost of Ownership

- Adjustable performance settings allow the truck to be tailored to the needs of the application, reducing energy consumption

- Regenerative braking reduces the use of the service brake and dissipates heat from the traction motor increasing the life of key components
- Motors and controllers are protected against damage and debris, reducing servicing and repair costs

Dependability

- The solid frame construction and industrial grade components ensure long-term reliability and durability
- A sturdy wrap around bumper plate protects the truck against impacts and damage and minimises repair costs
- The truck's electronics - including the enclosed AC traction motor, sealed combi-controller (with IP65 rating), sealed electrical connectors and hall effect sensors and switches - are all protected from damage to ensure excellent reliability, maximum productivity and reduced servicing costs
- Reduced wiring complexity is a result of the CANbus communication system, which also provides easy access to components and delivers world-class reliability

Serviceability

- The CANbus system and diagnostics can be controlled and monitored via the console or through the single plug-point. Fault codes can be displayed on the console for easy service identification
- A one-piece hood provides easy access to key components
- Full access to all the trucks main components, including the motor is, by the removal of the motor cover, which is retained by two easily removed screws
- The low maintenance AC traction motor with built in thermal protection is fully enclosed for protection against damage and debris, minimising service downtime

Available Options include:

- Side battery extraction
- Floor-level bumper (rubber bumper)
- Mid mounted bumper (bull bar)
- Universal support bar on motor compartment
- Several hook types
- Various drive wheel compounds, platform lift heights and storage compartments.

HYSTER-YALE UK LIMITED
trading as **Yale Europe Materials Handling**
Centennial House,
Frimley Business Park,
Frimley, Surrey GU16 7SG, United Kingdom.



Tel: +44 (0) 1276 538500 Fax: +44 (0) 1276 538559

www.yale-forklifts.eu



Publication part no. 220990225 Rev.01 Printed in The Netherlands (0617HG) EN.

Safety: This truck conforms to the current EU requirements. Specification is subject to change without notice.

Yale, VERACITOR and  are registered trademarks. "PEOPLE, PRODUCTS, PRODUCTIVITY", PREMIER, Hi-Vis, and CSS are trademarks in the United States and certain other jurisdictions. MATERIALS HANDLING CENTRAL and MATERIAL HANDLING CENTRAL are Service Marks in the United States and certain other jurisdictions.  is a Registered Copyright. © Yale Europe Materials Handling 2017. All rights reserved.

Truck shown with optional equipment. Country of Registration: England and Wales.

Company Registration Number: 02636775